

LIFT STATION SPECIFICATIONS

For

The Town of Lake Placid

1.00 Wet Well:

1.01 The wet well shall be reinforced concrete meeting ASTM C478-02a (or latest revision) Standard Specification for Pre-cast Reinforced Concrete Manhole Sections. Cement used in concrete composition shall be Type II acid resistant cement used for sanitary construction. Concrete shall attain a minimum compressive strength of 4000 psi at 28 days. Wall joints shall be tongue and grooved and so spaced that no piping shall pass through the wet well at a joint. Joints shall be suitable for the installation of Ram-Nek, shall have no voids or other imperfection, and shall be entirely watertight upon completion of construction.

1.02 Openings in the walls of the wet well for the passage of pipes may be made by the manufacturer at the time of fabrication or may be made in the field by the contractor, if desired. If holes are to be made in the field, their maximum dimension shall not exceed 1½ times the outside diameter of the pipe passing through the opening. Reinforced steel in the wall shall be cut cleanly and in no circumstances will cut ends be bent so as to turn to the inside or the outside surface. Openings so made shall be thoroughly filled with non-shrinking grout after installation of the pipes and special care shall be taken to insure a watertight connection at these points.

1.03 The concrete base upon which the wet well rests and the concrete top shall be constructed of Type II 4000 psi concrete, reinforced to comply with ASTM C-478-02a (or latest revision). The reinforced concrete top of the wet well will be constructed with a rectangular opening for access to the well. The pumps and/or accessories shall be secured to the concrete base in accordance with the manufacturer's recommendations. Minimum design for adequacy of base and top slab reinforcement is for AASHTO H-20 truck loading. The concrete base shall extend a minimum of 12" beyond the edge of the body of the wet well.

1.04 The wet well, including all surfaces top & bottom, shall be have a HDPE lining as stated on the plans. Shipping, handling, installation, cutouts, inserts and piping shall be in accordance with the specifications and requirements of the manufacturer. Shop drawings and Specifications of the proposed HDPE lining shall be submitted to the Engineer for Review.

1.05 The wet well shall be installed plumb and level on a 12" thick (minimum) compacted rock/stone bed.

2.00 Piping Inside Pump Station:

2.01 Piping inside the station wet well and above ground piping shall be ductile iron with flanged joints. Flanges shall be either welded or threaded to the connecting pipes. All fasteners inside the wet well and valve vault shall be stainless steel.

Ductile iron pipe shall be designed in accordance with the latest revision of ANSI/AWWA C150/A21.50 for a minimum 150 psi rated working pressure plus a 100 psi surge allowance; a 2 to 1 factor of safety on the sum of working pressure plus surge pressure;

Ductile iron pipe shall be manufactured in accordance with the latest revision of ANSI/AWWA C151/A21.51. Each pipe shall be subjected to a hydrostatic pressure test of at least 500 psi at the point of manufacture.

Pipe shall have standard asphaltic coating on the exterior. Pipe shall also have a cement-mortar lining on the interior in accordance with ANSI/AWWA C104/A21.4, of latest revision.

The class or nominal thickness, net weight without lining, and casting period shall be clearly marked on each length of pipe. Additionally, the manufacturer's mark, country where cast, year in which the pipe was produced, and the letters "DI" or "Ductile" shall be cast or stamped on the pipe.

Fittings shall be ductile iron. Fittings shall conform to the latest revision of either ANSI/AWWA C110/A21.10 or ANSI/AWWA C153/A21.53. Fittings and accessories shall be furnished with Mechanical Type Joints in accordance with ANSI/AWWA C111/A21.11, of latest revision.

All pipe, fittings and accessories shall be installed and tested in accordance with the latest revision of ANSI/AWWA C600.

3.00 Valves

3.01 Eccentric Type Plug Valves: Plug valves shall be non-lubricated eccentric type with resilient faced plugs having mechanical joint or flanged ends.

A. Port areas shall be at least 80% of full pipe area.

B. Valve seats, valve plug stem sleeves and plug stem bushings shall be fabricated of materials which are corrosion and abrasive resistant. The corrosion resistance shall be such that exposure over a period of five years to domestic wastewater, industrial wastewater, domestic sludge or industrial sludge containing sulfuric acid, hydrochloric acid, acetic acid, mineral oils, vegetable oils, polymers, esters or acetones shall not result in sufficient corrosion to interfere with the serviceability of the plug valve.

C. Seals shall be capable of being replaced while the line and valve remain in service, if under submerged conditions, thereby eliminating the need to take process units out of service.

D. All exposed nuts, bolts, springs, and washers shall be plated with corrosion resistant material. Means of actuation shall be by lever, gear actuator, tee wrench, extension stem, or floor stand, as indicated.

E. Valves shall be DeZurik Series 100, Homestead Ballcentric, Dresser Style 800 X-Centric, or equal.

3.02 Gate Valves: Buried gate valves 4-inch and larger shall be full iron body, epoxy fusion bonded inside and out, non-rising stem gate valves. Valves shall meet the requirements of ANSI/AWWA C500 and shall have mechanical joint ends. Mechanical joints and joint accessories shall meet the requirements of ANSI/AWWA A21.11/C111. Valve opening direction shall be consistent with operation of existing valves in the utility in which the valves are installed, unless otherwise directed by the Engineer.

A. Three-inch buried gate valves shall be iron body, non-rising stem gate valves. Valves shall meet the requirements of ANSI/AWWA C500, except ends shall be screwed. Screwed ends shall meet the requirements of ANSI B16.3. Valve opening direction shall be consistent with operation of existing valves in the utility in which the valves are installed, unless otherwise directed by the Engineer.

B. Gate valves 4-inch and larger installed above ground or in structures shall be iron body, outside screw, and yoke gate valves. Valves shall meet the requirements of ANSI/AWWA C500, except those parts of ANSI/AWWA C500 only applicable to non-rising stem gate valves and wrench nuts. Outside screw and yoke gate valves shall have flange joint ends and malleable iron hand wheels. Flange joints and accessories shall meet the requirements of ANSI/AWWA C110. Nuts and bolts shall be cadmium plated. Gaskets shall be full face and shall be Velumoid, or equal.

C. Gate valves smaller than 4-inch installed above ground or in structures shall be bronze, 125 lb. S.W.P. double disc, screwed-in bonnet, rising stem, inside screw gate valves with screwed ends and malleable iron hand wheels. Valves shall meet the requirements of Federal Specification WW-V-54d for Class A, Type III valves.

3.03 Check valves shall be Swing Check Valves with outside weighted arm, iron body, bronze mounted, Mueller or approved equal.

4.00 Rails, Fasteners, Lift Chains

4.01 Pump rails shall be 304 stainless steel, at nominal diameter, recommended by manufacturer. Minimum diameter shall be 1½ inches.

4.02 All fasteners and hardware inside the wet well and valve vault shall be stainless steel.

4.03 Lift chains shall be stainless steel. Check valves shall be Swing Check Valves with outside weighted arm, Mueller or approved equal.

5.00 Access Frame and Cover

5.01 A door access frame assembly shall be furnished for the wet well and valve box. The access frame cover shall be capable of bearing a 300 pounds per square foot (psf) live load. Access frame and covers shall be fabricated of aluminum. Frame shall support stainless steel guide rails and stainless steel cable holder. A separate hinged cover shall be provided with lifting handle and safety latch to hold cover in the open position. Locking hasps shall be furnished for each cover. Frame and access cover shall be manufactured by Halliday Products; or equal. The entrance latch shall be constructed and fabricated to comply with the OSHA standards. All surfaces in contact with concrete shall have a shop coat of zinc chromatic primer, approved alkali resistant paint or other approved protective coating. Cover must be compatible with pumps and guide rail system. All hardware, including anchors, bolts, hasps, hinges, guides and cable holders shall be stainless steel.

5.02 A Yale Model 945, or approved equal, solid brass pad lock for each hatch cover shall be supplied. Locks shall be keyed alike with a minimum of 5 keys provided to the owner.

6.00 Pumps

Davis/EMU Pumps as noted on the plans shall be used. No substitutions.

7.00 Panel

To be supplied by the pump manufacturer. **See spec sheet at end - No. 16.0**

8.00 Generator

Receptacle shall be 4 prong type and matched to fit the Town of Lake Placid portable generator.

9.00 Telemetry

Not Required.

10.00 Drop Pipes, if required, shall be RELINER® Inside Drop System by Duran Inc., no substitution.

11.00 Shop Drawings

Shop drawings showing details of Construction shall be submitted to the Project Engineer for approval prior to any construction. Also furnish a duplicate set to the Town of Lake Placid Director of Utilities

12.00 Record Drawings and Operation and Maintenance Manual

Upon completion of the project and prior to final payment the Contractor shall supply record drawings of the lift station and provide an operation and maintenance manual detailing all equipment used and describing proper operation procedures and required maintenance procedures. Four copies are to be supplied with proper cover labeling.

13.00 Start-up

13.01 During construction, the services of a manufacturer's representative shall be provided, without cost to the Owner, to inspect the various items of equipment during construction as well as prior to placing into operation. In addition to these inspections, the services of the manufacturer's representative will be required to provide consultation during initial station start-up and for a period thereafter to instruct the Owner's utility personnel in the operation of the sewage pumping equipment.

13.02 After erection, the Contractor shall demonstrate that all equipment is operating in a satisfactory manner. All equipment shall be lubricated according to recommendations of the manufacturers and all adjustments shall be made to suit anticipated operations. Each piece of equipment shall be tested to show that it operates quietly, without vibration, overheating, or signs of distress, at full capacity. Adjustments shall be made as necessary. All defective parts of machinery shall be replaced.

14.0 Warranties

14.01 There shall be a full one year warranty on all construction and equipment from the date of final inspection.

15.0 Low-Pressure Sewer Simplex or Duplex Grinder Package

15.01 Simplex or Duplex Grinder Package including 2 hp pumps with twenty (20) foot cords, float pump switches with twenty (20) foot cords, 220 volt electric control box and switches. The tank Basin and Lid are to be manufactured of FRP (Fiberglass Reinforced Polymers) with a wall thickness of one-quarter ($\frac{1}{4}$) to three-eighth ($\frac{3}{8}$) inch. The Simplex Basin is to be 36 x 48 inches equaling 211 gallons and the Duplex Basin is a 48 x 72 inch size, giving a capacity of 560 gallons. This complete package **shall be manufactured only by Alpha General Services, Inc, with no substitutions.**

16.0 Lift Station Panel Specifications

See next page 6...

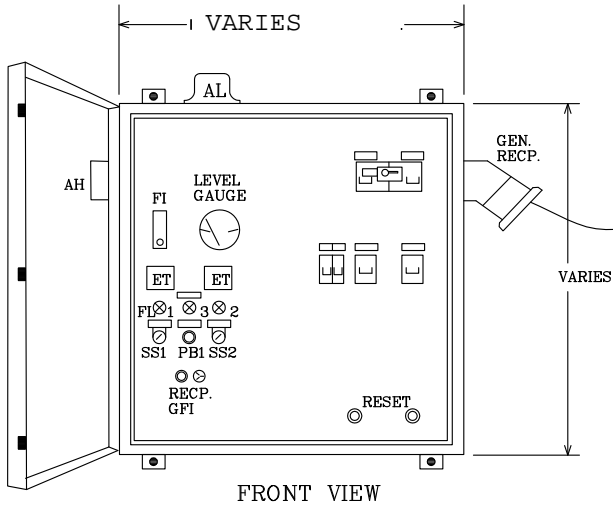

EMERGENCY GENERATOR RECEPTACLE (FOUR PRONG CONNECTION AS PER THE TOWN OF LAKE PLACID'S PORTABLE GENERATOR.)
(NEED TO VERIFY WITH THE TOWN OF LAKE PLACID)

FRONT VIEW

- 1-ENCLOSURE NEMA 3R STAINLESS STEEL.
- 2-MATERIAL 34 GAUGE 0304 STN. STL.
- 3-CONSTRUCTION FORMED AND WELDED.
- 4-FINISH NO. 23 BRUSHED.
- 5-HINGE CONTINUOUS STAINLESS STEEL.
- 6-GASKET RUBBER EDGE TYPE.
- 7-LATCHES STAINLESS STEEL DRAW DOWN TYPE.

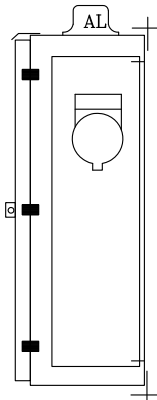

SIDE VIEW

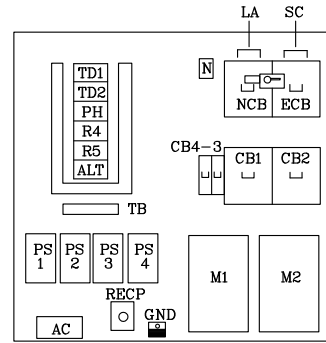

BACKPLATE

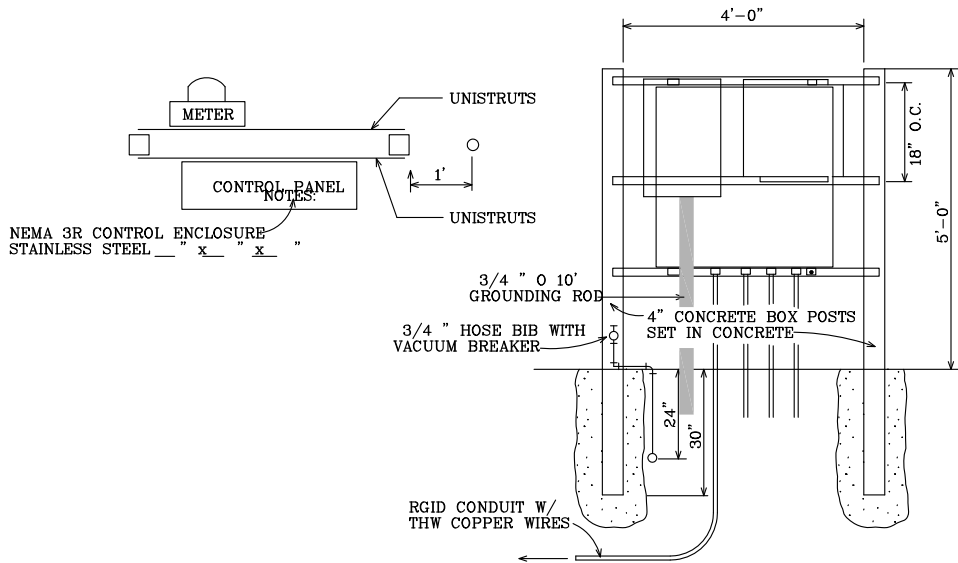

CONTROL PANEL MOUNTING DETAIL

N.T.S.

TOWN OF LAKE PLACID - LIFT STATION ELECTRICAL PANEL SPECIFICATIONS

Note: All Lift Station Control Panel Float Switches to be supplied by the Bidder.

Each new Lift Station Control Panel to consist of the following:

- (A) NEMA 4X Enclosure (36”H x 30”W x 12”D) 304 Stainless Steel, 3 Point Latching with draw-down Hurricane clamps, Lockable, with Hinged Cover and a .150 Mill Grade Aluminum swing panel with a minimum of two heavy duty door latches. (Swing Panel must be cut CNC or machine cut. (no manual cut-outs will be accepted).
- (B) Two 7.5HP 3P NEMA Size1 SqD Motor Starters with standard overloads and reset buttons. *
- (C) Control Panel Breakers:
 - 1 120v 1P 10A Control Circuit Breaker (SqD Type QOU)
 - 2 240v 3P 70A Emergency/Main SqD HDL Type Circuit Breakers with a mechanical UL Listed slide bar type interlock.
 - 2 240v 3P 45A SqD Type HDL Motor Circuit Breakers
 - 1 120v 1P 15A GFCI Receptacle Circuit Breaker (SqD Type QOU)
- (D) Typical Duplex Pump Lift Station Control with (4) float switch control.
- (E) 1 Ingram Alarm Horn, Light, and Alarm Silence Push Button.
- (F) 1 Diversified Duplex Pump Alternator with integral Load Select toggle switch.
- (G) 2 Reddington #3100-1000 Elapsed Time Meters.
- (H) 1 120v 15A Hubble #5262 GFCI Receptacle.
- (I) 1 SqD Lightning Arrestor
- (J) 1 Diversified Phase Monitor.
- (K) 2 SqD NEMA 4X Type SK Hand/Off/Auto Selector Switches
- (L) 2 SqD Type SKP Motor Run Lights (Green Color Cap)
- (M) 2 Motor Thermal terminals with Latching Circuit, requires manual reset
- (N) 2 SqD Type SK Thermal Fault Pilot Lights (Red color caps)
- (O) 2 SqD Type SK Manual Fault Reset Push Buttons.
- (P) 2 Diversified Time Delay Relays (Lag Start and Alarm)
- (Q) 1 120V/24V 100VA Transformer for Float Switch Logic
- (R) 1 240v 3P 100A Russellstoll Generator Receptacle with Angle Adapter.
- (S) 1 Alternator Test Switch.
- (T) 4 Roto-Float Switches.
- (U) Lot Color coded control wiring with color coded matching terminal blocks mounted on a 45 degree angle bracket for ease of field wiring terminations.
Color Code as follows: Red – AC Wiring, Black – Line Voltage, White – Neutral, Yellow – Remote Voltage Source, Green – Common Ground, Blue – DC+, Blue w/ White Stripe – DC-
- (V) 4”H x 4”W back panel wire way; no exceptions
- (W) Laminated ‘As Built’ schematics to be attached to the interior door
- (X) Laminated ‘As Built’ Bill of Materials to be attached to the interior door
- (Y) Panel must be UL Listed
- (Z) Panel’s must be witness tested prior to shipment
- (AA) Provide a complete set of submittal documents (shop drawings, BOM, cut-sheets) for each 7.5 HP and 15.4 HP panel with the bid documents. Exclusion of these documents will eliminate the bidder.

Note:* (B) Some of the Lift Stations have 15.4 hp and 20 hp motors instead 7.5 hp; Make adjustments accordingly.

END OF SPECIFICATION FOR NEW LIFT STATION CONTROL PANELS

NOTICE: LOCAL BUSINESSES AND /OR DRUG FREE WORKPLACES SHALL BE GIVEN PREFERENCE IN THE EVALUATION AND AWARD OF PURCHASES AND CONTRACTS.

END OF LIFT STATION SPECIFICATIONS